

NOTE: ID BEARING SELECTING THIS
 LEWIS-1815K-1 DRAWING IS THE PROPERTY OF LEWIS PRODUCTS, INC. IT IS TO BE USED ONLY FOR THE PART IDENTIFIED HEREIN AND NOT TO BE REPRODUCED OR TRANSMITTED IN ANY FORM OR BY ANY MEANS, ELECTRONIC OR MECHANICAL, INCLUDING PHOTOCOPYING, RECORDING, OR BY ANY INFORMATION STORAGE AND RETRIEVAL SYSTEM. WITHOUT THE WRITTEN PERMISSION OF LEWIS PRODUCTS, INC. THIS DOCUMENT IS UNCLASSIFIED BY DATE 10/21/2011 AND IS IN THE PUBLIC DOMAIN.

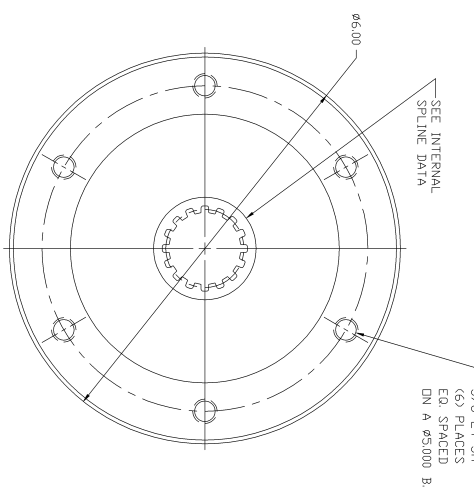

INTERNAL SPLINE DATA SPECIFICATION
 DIAMETRAL PITCH ---- 20/30
 PRESSURE ANGLE ---- 30°
 NO. OF TEETH ---- 24
 T.L.F. DIAMETER ---- 1.273 MIN.
 MINOR DIA. (REF.) ---- 1.133 $\pm .005$
 PITCH DIA. (REF.) ---- 1.2000

EXTERNAL SPLINE DATA SPECIFICATION
 DIAMETRAL PITCH ---- 20/30
 PRESSURE ANGLE ---- 30°
 NO. OF TEETH ---- 24
 T.L.F. DIAMETER ---- 1.127 MAX.
 MAJOR DIA. (REF.) ---- 1.267 $\pm .008$
 PITCH DIA. (REF.) ---- 1.2000

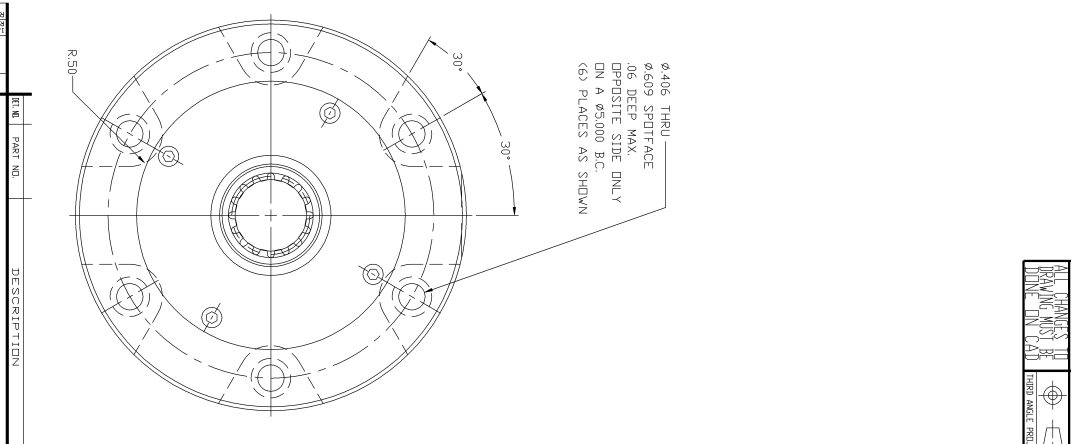
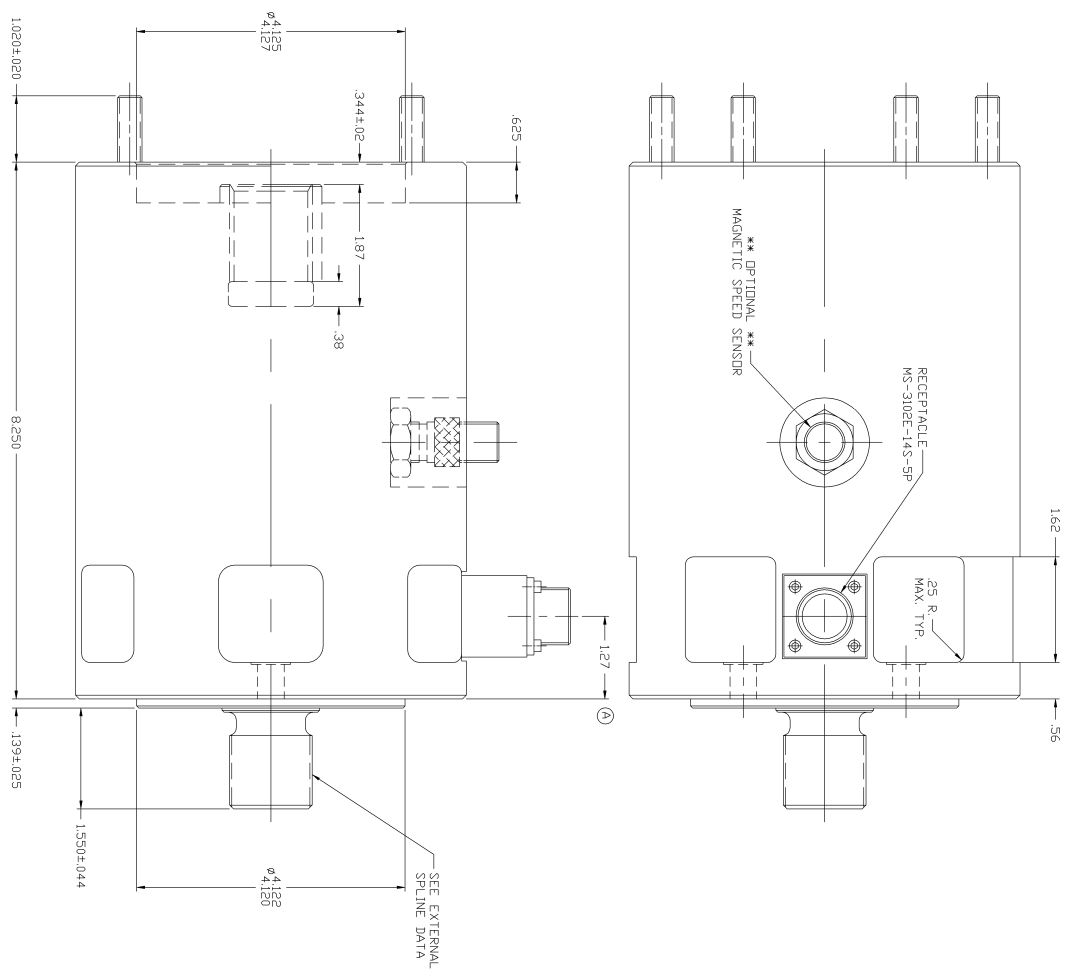

SPECIFICATIONS
 CAPACITY AVAILABLE --- 5,000 OR 10,000 LBS IN
 CAPACITY OVERLOAD --- 300% AT 5,000 LBS IN
 150% AT 10,000 LBS IN
 OUTPUT --- 2.0 NV/V NOMINAL
 AT RATED CAPACITY
 SPEED --- 15,000 RPM MAX.
 TEMPERATURE RANGE --- MUST NOT EXCEED 225°F
 MOUNTING MOUNTING FLANGE AND DRIVE REFERENCE
 AIR-FORCE-NAVY AERONAUTICAL DESIGN STANDARD
 ND. AND 20002 & AND 10262

REV	DATE	DESCRIPTION
1		REVISIONS
2		REVISIONS
3		REVISIONS
4		REVISIONS
5		REVISIONS
6		REVISIONS
7		REVISIONS
8		REVISIONS
9		REVISIONS
10		REVISIONS
11		REVISIONS
12		REVISIONS
13		REVISIONS
14		REVISIONS
15		REVISIONS
16		REVISIONS
17		REVISIONS
18		REVISIONS
19		REVISIONS
20		REVISIONS
21		REVISIONS
22		REVISIONS
23		REVISIONS
24		REVISIONS
25		REVISIONS
26		REVISIONS
27		REVISIONS
28		REVISIONS
29		REVISIONS
30		REVISIONS
31		REVISIONS
32		REVISIONS
33		REVISIONS
34		REVISIONS
35		REVISIONS
36		REVISIONS
37		REVISIONS
38		REVISIONS
39		REVISIONS
40		REVISIONS
41		REVISIONS
42		REVISIONS
43		REVISIONS
44		REVISIONS
45		REVISIONS
46		REVISIONS
47		REVISIONS
48		REVISIONS
49		REVISIONS
50		REVISIONS
51		REVISIONS
52		REVISIONS
53		REVISIONS
54		REVISIONS
55		REVISIONS
56		REVISIONS
57		REVISIONS
58		REVISIONS
59		REVISIONS
60		REVISIONS
61		REVISIONS
62		REVISIONS
63		REVISIONS
64		REVISIONS
65		REVISIONS
66		REVISIONS
67		REVISIONS
68		REVISIONS
69		REVISIONS
70		REVISIONS
71		REVISIONS
72		REVISIONS
73		REVISIONS
74		REVISIONS
75		REVISIONS
76		REVISIONS
77		REVISIONS
78		REVISIONS
79		REVISIONS
80		REVISIONS
81		REVISIONS
82		REVISIONS
83		REVISIONS
84		REVISIONS
85		REVISIONS
86		REVISIONS
87		REVISIONS
88		REVISIONS
89		REVISIONS
90		REVISIONS
91		REVISIONS
92		REVISIONS
93		REVISIONS
94		REVISIONS
95		REVISIONS
96		REVISIONS
97		REVISIONS
98		REVISIONS
99		REVISIONS
100		REVISIONS

Lebow Products
 Troy, Michigan

Drawing Scale
 1:1

Part No.
 1815K-1

Revision
 1

Quantity
 1

Material
 303 STAINLESS STEEL

Finish
 1815K-1

Notes
 1. SEE INTERNAL SPLINE DATA
 2. SEE EXTERNAL SPLINE DATA
 3. 3/8-24 3A (6) PLACES EQ. SPACED DN A $\phi 5.000$ B.C.
 4. $\phi .406$ THRU $\phi .609$ SPT/FACE .06 DEEP MAX. OPPOSITE SIDE ONLY DN A $\phi 5.000$ B.C. (6) PLACES AS SHOWN